

Model:

- ▶ Touchscreen Hot Water Dispenser HWB-2105XTS & HWB-2110XTS



HWB-2105 and HWB-2110 5 & 10 gallon per hour heavy-duty commercial hot water dispensers

HWB-2100XTS USERS GUIDE-North America Edition



NOTICE TO INSTALLER: Please leave this book with the machine.

Table of Contents

Contact Information	2	Accessing Service Screens and Controls	5
Description & Features	2	Error Codes	10
Specifications.....	2	Installation Instructions.....	11
Electrical Rating Chart.....	2	Safety Notes	12
Dimensions & Utility Connections.....	3	Parts and Service drawings.....	14
Operating Instructions	4	Wiring Diagrams	23

FETCO®, XTS are trademarks or trade names of Food Equipment Technologies Company.

Contact Information

FETCO®
 Food Equipment Technologies Company
 600 Rose Road
 Lake Zurich • IL • 60047-0429 • USA

Phone: (800) 338-2699 (US & Canada)
 (847) 719-3000
Fax: (847) 719-3001

Email: sales@fetco.com
 techsupport@fetco.com

Internet: www.fetco.com

Description & Features

The following are the factory settings—and range of variables that are adjustable:

Temperature Control: Water temperature is factory set at maximum 96°C/205°F
 (Temperature selectable 50-97°C/122°-208°F)

HWB-2105 Output Capacity: At least 19 liters/ 5 gallons of 96°C/205°F temperature hot water per hour

HWB-2110 Output Capacity: At least 38 liters/10 gallons of 96°C/205°F temperature hot water per hour

Commercial electrical requirements below

Specifications								
FETCO HWB-2105 and HWB-2110 5 & 10 gallon per hour heavy-duty commercial hot water dispensers								
Capacities & Measurements								
Dispenser	Height	Width	Depth	Empty Weight	Filled Weight	Hot Water Tank Capacity	Shipping Weight	Shipping Dimensions
HWB-2105	31½" 800mm	8" 203mm	22¼" 565mm	29 lb 13.2kg	55 lb 25 kg	4.4 gal 17.6 l	44lb 20kg	35inx11inx25in 889mmX279mmX635mm
HWB-2110	31½" 800mm	11" 279mm	22¼" 565mm	47lb 21.3kg	92lb 41.7kg	8.0 gal 30 l	59lb 26.8kg	35inx15inx27in 889mmX381mmX686mm

Electrical Rating Chart								
Configuration Code	Heater Configuration	Voltage	Phase	Wires	Electrical Connection	kW	Maximum Amp draw	Flow Rate Per hour*
5 gallon North America Configuration -UL, cUL, NSF approved								
B210551	1 X 3 kW	208-240	single	2+G	Terminal Block-Hardwire	3.1	12.9	5 Gal/19 liters
B210552	1 X 4 kW	208-240	single	2+G	Terminal Block-Hardwire	4.1	17.1	5 Gal/19 liters
10 gallon								
B211051	2 X 3 kW	208-240	single	2+G	Terminal Block-Hardwire	6.1	25.4	10Gal/38 liters
B211052	2 X 4 kW	208-240	single	2+G	Terminal Block-Hardwire	8.1	33.8	10Gal/38 liters
*Flow rate based on 65°F/18.3°C water mains supply and dispensing from ("■" "READY" status)								

Dimensions & Utility Connections

HWB-2105

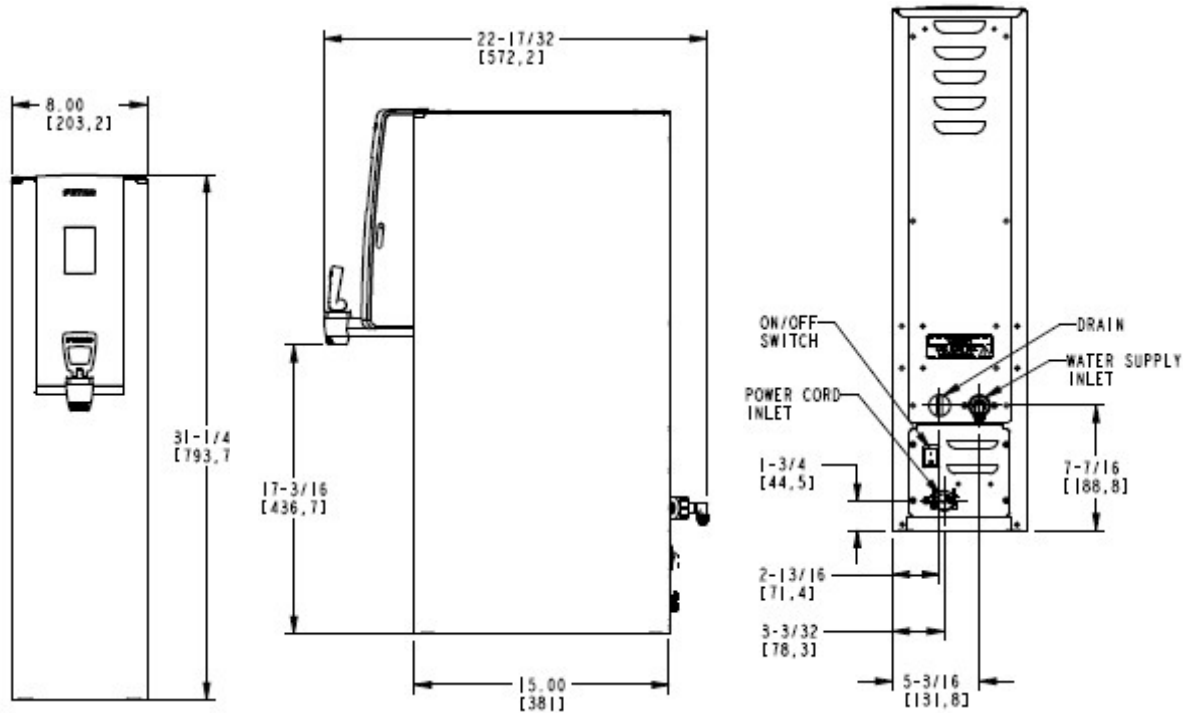

DRG 1201.00015.00

HWB-2110

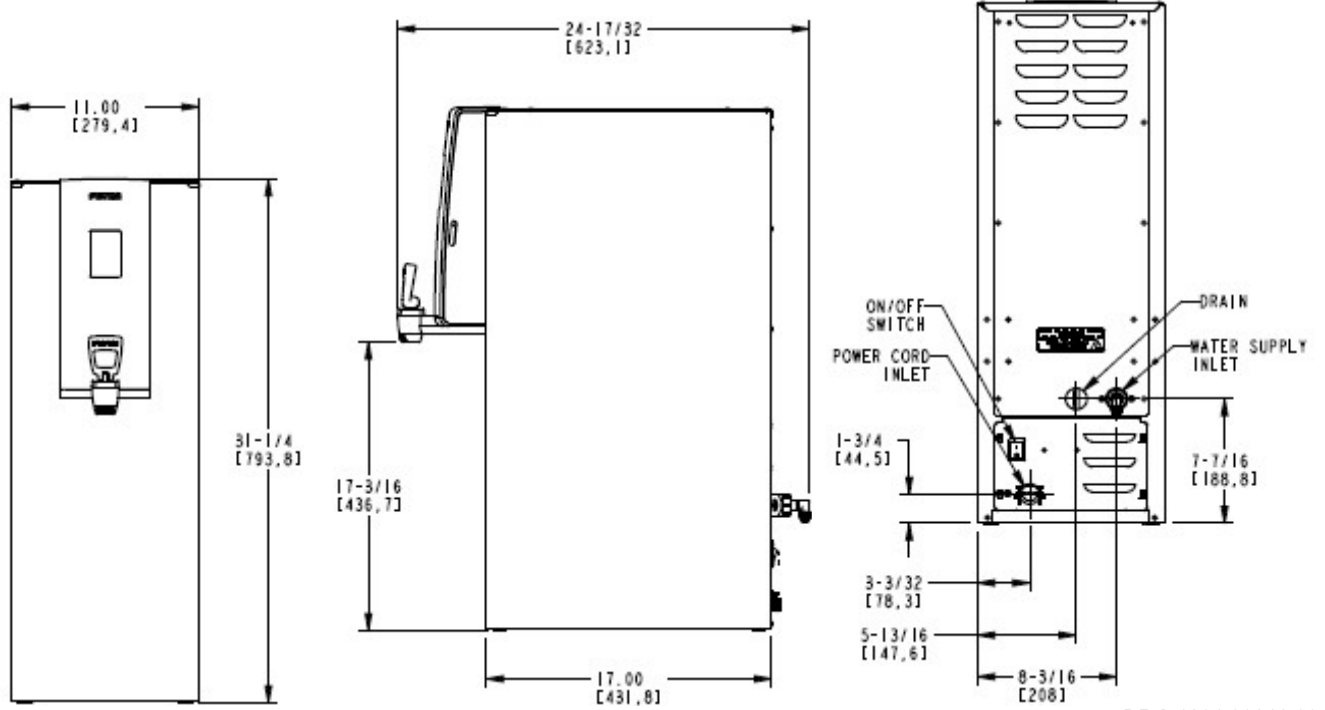

DRG 1201.00016.00

Operating Instructions

Follow instructions on pages 11-13 to install electrical and plumbing utilities. Turn on water supply. Turn rocker switch "ON". Switch is on the back of the equipment, at lower right. The HWB will begin filling and heating taking 15-30 minutes to complete and the READY Icon to display. The HWB may need to be turned "OFF" and restarted from the power switch if initial fill is too slow. When the READY Icon displays, the machine in operation will dispense hot water at displayed temperature. Equipment is now ready to use.

NOTE: For best results-leave the HWB "ON". FETCO hot beverage equipment is well insulated and is designed to be left "ON" overnight. An optional, automatic digital power saver ECO Mode may be activated if desired.

Temperature is factory set for 205°F/96°. Setting may be changed from Programming Screens, or as below. Operator controls, if activated, may be accessed by touching and holding lower part of screen.
 -Hot water tank temperature may be selected using slider
 -Equipment may be turned off and on from touch screen, touch screen will display "OFF" status.

Starting Screens



First Screen: Unit started: And is Filling and Heating

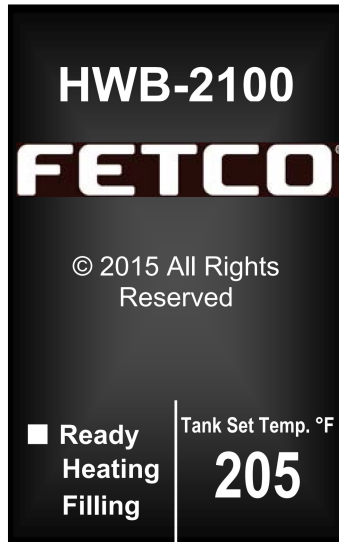

Unit "READY" to dispense



Hold finger on lower touch screen to access OPERATOR ACCESS SCREENS and programming menu screens

Operator Access Screens

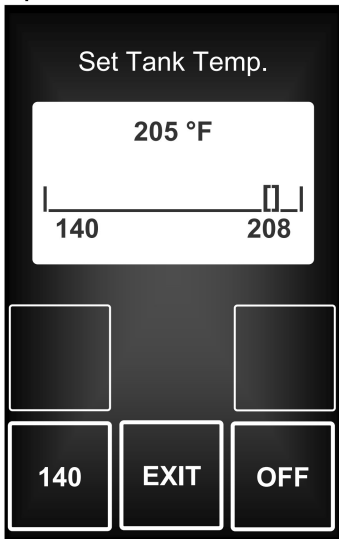

Operator Access is disabled. To enable, go to PROGRAMMING, OTHER, ALLOW EDIT TEMP



ECO mode icon displayed Unit is in ECO mode after being idle for more than four hours

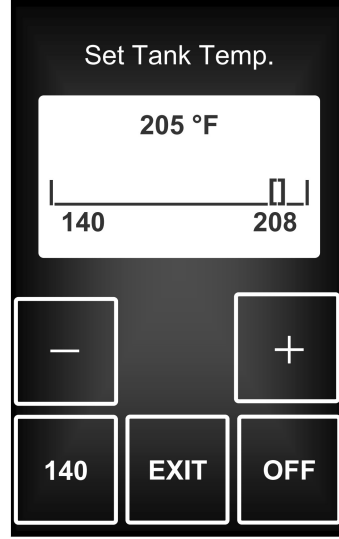

"Operator Access Controls" Are enabled, (the -&+ icons show)

If Operator Access is disabled (+ & - icons are dark), temperature will display, but cannot be adjusted. Energy Saving "ECO" Mode may be activated by touching "140" icon. Touch: "EXIT" icon to turn off ECO Mode.

Operator Access Screens, Continued

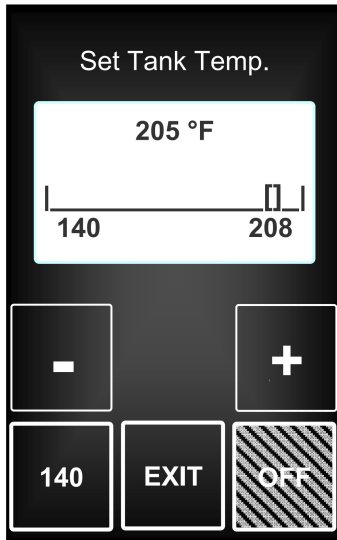

"OFF" button turns unit "OFF"

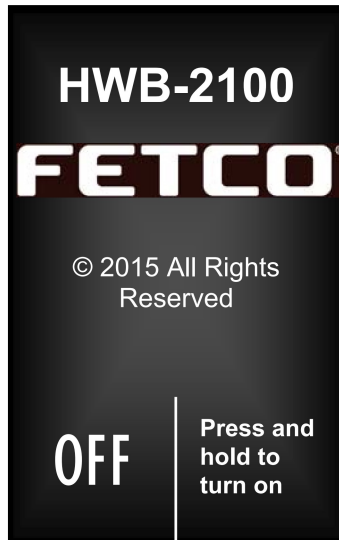

Press and hold to progress to control screen (to right) to turn on the HWB-2100



Control screen to turn unit off or on

Accessing Service Screens and Controls

Control parameter settings, programming, error codes, counters and reset features are accessed by activating touch screens. To enter the Operator Access Controls touch the lower display and hold. Access to Operator Access Controls must be enabled from the Service Menu screens (under: OTHER—"Allow Edit Temp").

For programming the Service Menu, to see diagnostics and to enable all Operator Access Controls:
1) Turn main power switch "OFF" (lower rear of the HWB-2100), after >10 seconds turn "ON"



← TO ENTER PROGRAMMING

From Power "OFF" state
Turn power switch "ON"
Within 5 seconds of display shown
Touch and hold to enter the programming screens.

(Entering *Service Screen shown below*)

To enter operator service screens
← From any screen, touch and hold lower display on screen to access the "Operator Access Controls"

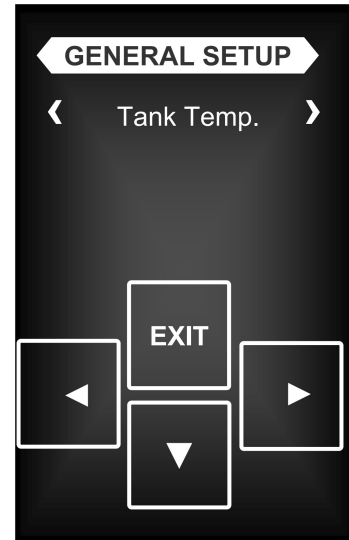

First Service Screen to show when entering "GENERAL SETUP"
Use arrow icons to scroll through the menu. The DOWN icon will open the FEATURE icon below. Scroll through the FEATURE icon with the arrows EXIT and save changes.

Service Menu

General Service Menu, Inputs Service Menu, Outputs Service Menu and Other Service Menu.

-Enter Service Menu by accessing the power switch on back of the panel—switching into Power “OFF” state

-After at least thirty seconds: Turn power switch “ON”

-Touch and hold Upper HWB Logo to enter the programming screens.

-When entering The SERVICE MENU: the first screen is “GENERAL SETUP”

-Use right and left arrow icons to scroll through the four main SERVICE menus.

-The DOWN icon will open the FEATURE icon below.

-Scroll through the FEATURE icon with the arrows EXIT and save changes

-A Menu Tree is below to show the main categories of the four SERVICE menus.

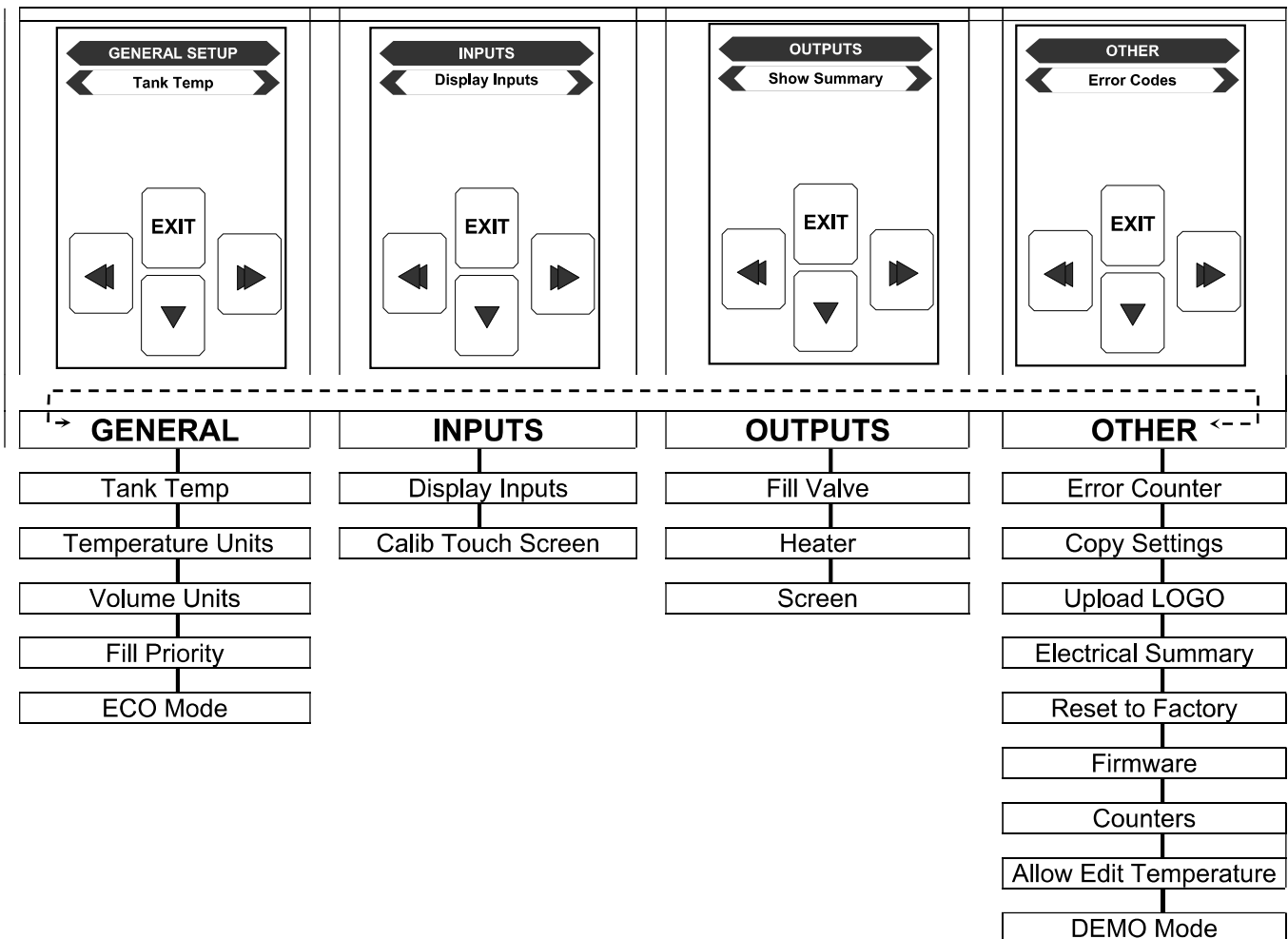

First Service Menu screen: GENERAL

GENERAL	Programming Items	Factory set Default	Programming Range (display)	Notes
Tank Temp.		205°F/96°C		Correction for high altitude below
Temp Units	• Temperature	°F		
Vol Units	• Volume	US G		US gallons differ from UK (Imperial) gallons
Priority	• Temperature • Volume	Volume is default		Refill rate: "Slower" Refill rate: "Quick"
ECO Mode		NORMAL		See chart below

*Refill rate TEMPERATURE may be slower at large volume dispense, and will stay closed to set temperature

ECO Mode option, screen definitions

"ECO" mode, or digital power economy control feature may be activated to save energy in standby state.
 If selected, after four hours of non-use—controls automatically lower the tank temperature to 140°F/60°C, or can be selected to turn heaters "OFF"
To restore set temperature:
 Touch the screen to come out of ECO mode

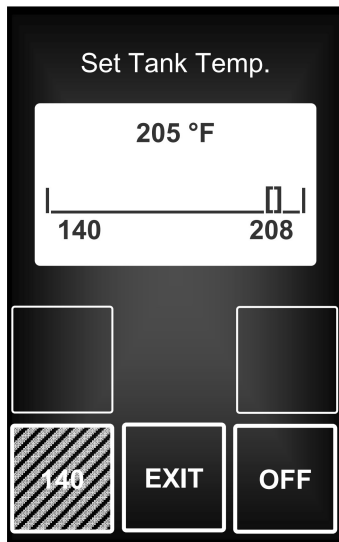

TO activate ECO Mode:
 FROM Operator access screen:
 Press "140"



ECO mode icon displayed
 Unit is in ECO mode after being
 idle for more than four hours

All FETCO commercial hot beverage equipment have well insulated hot water tanks to limit energy consumption. Effective insulation increases equipment life and lowers building HVAC costs. FETCO has the best energy savings of all major suppliers.

Chart to correct for altitude for boiling point in tank water temperature.

[ft]	[m]	Suggested Setting[°F]	Boiling point[°F]	Suggested Setting[°C]	Boiling point [°C]
0	0	205	212.0	96	100.0
500	152	205	211.0	96	99.5
1000	305	200	210.1	93	98.9
2000	610	200	208.1	93	97.8
2500	762	200	207.2	93	97.3
3000	914	200	206.2	93	96.8
3500	1067	197	205.3	92	96.3
4000	1219	195	204.3	91	95.7
4500	1372	194	203.4	90	95.2
5000	1524	194	202.4	90	94.7
5500	1676	193	201.5	89	94.2
6000	1829	192	200.6	89	93.6
6500	1981	191	199.6	88	93.1
7000	2134	190	198.7	87	92.6
7500	2286	188	197.8	86	92.1
8000	2438	187	196.9	86	91.6
8500	2591	185	196.0	85	91.1

Service Menu screens, continued: Second/Third Service Menu screen INPUTS & OUTPUTS

INPUTS	Programming Items	Factory set Default	Programming Range (display)	Notes
Display Inputs	• Input Summery		Level probe Low <input checked="" type="checkbox"/> Level probe High <input checked="" type="checkbox"/> Temp. Probe 1 <input type="checkbox"/> Temp. Probe 1 205F Temp. Probe 2 <input checked="" type="checkbox"/> Temp. Probe 2 158F SD Card present <input type="checkbox"/> Float Switch <input checked="" type="checkbox"/>	
Cal. Touch Scr		Calibrate	Calibrate _____ <input type="checkbox"/> YES NO	If Yes: Follow directions on the touch screen

OUTPUTS	Programming Items	Factory set Default	Programming Range (display)	Notes
Fill Valve	• Fill Valve Test	(Press to test)	TEST Press To Test <input type="checkbox"/>	Operates fill valve. Have container under both brewbaskets!
Heater	• Heater Test	(Press to test)	TEST Press To Test <input type="checkbox"/>	Energizes Heater(s) Use for servicing.
Screen	• Screen Contrast	Contrast	8 ----- <input type="checkbox"/> 1 10	
	• S. Brightness	Brightness	8 ----- <input type="checkbox"/> 1 10	



Unit shown in
"DEMO MODE"
(Bottom Page 9) →

Service Menu screens, continued: Fourth Service Menu screen: OTHER

OTHER	Programming Items	Factory set Default	Programming Range (display)	Notes
Error Codes	• Display Errors	(Codes)	ERRORS Last 4 errors 202 101 200 200 (most recent at bottom)	Chart is below
	• Reset Errors	(Reset)	Reset <input type="checkbox"/> YES <input type="checkbox"/> NO	!!Errors must be corrected and cleared!!
Copy Settings	• From SD to B.	SD → HWB	SD → Brewer <input type="checkbox"/> YES <input type="checkbox"/> NO	Setup upload Please insert SD card with the setup data!
	• From B to SD	HWB → SD	Brewer → SD <input type="checkbox"/> YES <input type="checkbox"/> NO	Setup upload Please insert SD card with sufficient space (≥2GB)
Upload Logo		Upload Logo	UPLOAD LOGO Are you sure <input type="checkbox"/> YES <input type="checkbox"/> NO	Please insert SD card with logo file!
Electrical Summary			Electrical Configuration Summary Model Number † 2105 (or) 2110 Heater Power † 3.0 kW (or) 4.0 kW Heaters Number 1 (or) 2 Mains Voltage † 208 (or) 240 Tank Capacity 4.9 (2105) (or) 9.5 In. water temp. † (2110) Valve flr 62°F 0.66 GPM	† Values must be entered when Resetting to factory defaults. Values displayed (left) are most common and generally useable.
Res to Factory		Reset to default †	Reset to Default Are you sure <input type="checkbox"/> YES <input type="checkbox"/> NO	† Values must re-entered as seen in "Electrical Summary" screen (ABOVE)
Firmware	• Firmware Version -Software type	Firmware Version	SW ver. _ _ _ _ HW ver BL ver. _ _ _ _ QP ver. _ _ _ _	Displays current firmware version
• Update Firmware	UPDATE	UPDATE <input type="checkbox"/> YES <input type="checkbox"/> NO	Firmware upload Please insert SD card with the firmware file!	• Update Firmware
Counters	• Display Counters -OR- • Reset Counters	Counters Display Total Counters	Total Counters Valve pulses 0-∞ Valve-on xxm yys Water Vol. 1.0 US G Heater pulses 5 Heater-on 46s Energy consumed 57.5 Wh Power-ups 41 ON time 3h 40m 18s Touch To Return	Resetting will restart counter from zero
	• Reset Counters	Reset All Counters	Reset All Counters* Are you sure <input type="checkbox"/> YES <input type="checkbox"/> NO	
Allow Edit Temp	• Turns control ON/OFF		Enable User Mode <input type="checkbox"/> NO <input type="checkbox"/> YES	If YES, operator can adjust the tank temperature.
DEMO Mode ← (Example)		Allows controls to function without machine in operation	Demo Mode <input type="checkbox"/> YES <input type="checkbox"/> NO	Operation Display screen shows "DEMO" →

DEMO

Error Codes

Description		Recommended Corrective Action for Service	Remedy
OK	0	No error	
SOFTWARE ERROR	2	There was a problem with the internal program	replace board
EE CRC WRONG	4	The internal data memory malfunction (EE CRC)	replace board
TEMP SENSOR SHORT 1	50	Short circuit in temperature probe T1	Check board or probe
TEMP SENSOR OPEN 1	51	Temperature probe circuit is open T1	Check board or probe
TEMP SENSOR SHORT 2	50	Short circuit in temperature probe T2	Check board or probe
TEMP SENSOR OPEN 2	51	Temperature probe circuit is open T2	Check board or probe
PREFILLING TOO LONG	100	Tank initial filling is taking too long	Water turned off, clogged filter, Turn equipment off, restore power, clear error, and proceed
OVER FLOW	103	Tank Overflow Error - May be boiling 1-Hot water tank may be steaming or boiling due to altitude.	Liquid level probe fault, Correct temperature set point for altitude, see chart page-7.
XCHANGED	106	The LLC probes' connectors have been reversed	Turn equipment off, service probes, restore power, clear error, and proceed
TANK WATER LEVEL IS TOO LOW	107	The tank has been drained beyond the low level sensor.	Check for Tank leakage, water turned off.
EMPTY TANK OVERHEAT	114	Temp. probe fault - empty tank is too hot	Turn equipment off, allow to cool, service fault, restore power, clear error, and proceed
TEMP ≥100C	115	Temp.probe fault – the temp is above water boiling point. Possible bad probe	Turn equipment off, allow to cool, service fault, restore power, clear error, & proceed
WATER BOILING	200	e.g. user set temp 90°C & water boils at 85°C	Check probe position, check heaters Also see Error Eode 103-above
HEATER OPEN	201	Heater circuit is open	Heater open, high limit thermostat,
SSR SHORTED	202	The Solid State Relay failed (short circuit)	Solid State Relay (SSR) fault
POWER CYCLE NEEDED	254	Machine needs to be power cycled to write new values to the EEPROM memory	Power cycle the machine (Turn OFF-Then ON)
TOUCH SCREEN	255	A problem with the LCD Touch Screen, touched too long (>2 min)	Power cycle the machine (Turn OFF-Then ON)

Display Inputs (See “INPUTS” Service Screen)	<table style="width: 100%; border-collapse: collapse;"> <tr> <td style="padding: 2px;">Level probe Low</td> <td style="text-align: right; padding: 2px;">■</td> </tr> <tr> <td style="padding: 2px;">Level probe High</td> <td style="text-align: right; padding: 2px;">■</td> </tr> <tr> <td style="padding: 2px;">Temp. Probe 1</td> <td style="text-align: right; padding: 2px;">□</td> </tr> <tr> <td style="padding: 2px;">Temp. Probe 1</td> <td style="text-align: right; padding: 2px;">215F</td> </tr> <tr> <td style="padding: 2px;">Temp. Probe 2</td> <td style="text-align: right; padding: 2px;">■</td> </tr> <tr> <td style="padding: 2px;">Temp. Probe 2</td> <td style="text-align: right; padding: 2px;">158F</td> </tr> <tr> <td style="padding: 2px;">SD Card present</td> <td style="text-align: right; padding: 2px;">□</td> </tr> <tr> <td style="padding: 2px;">Float Switch</td> <td style="text-align: right; padding: 2px;">■</td> </tr> </table>	Level probe Low	■	Level probe High	■	Temp. Probe 1	□	Temp. Probe 1	215F	Temp. Probe 2	■	Temp. Probe 2	158F	SD Card present	□	Float Switch	■
Level probe Low	■																
Level probe High	■																
Temp. Probe 1	□																
Temp. Probe 1	215F																
Temp. Probe 2	■																
Temp. Probe 2	158F																
SD Card present	□																
Float Switch	■																
<p style="font-size: small;">Use DISPLY INPUTS screen to assist in error code fault correction. There are two Temp.Probes shown as Temp Probe1&2 Temp Probe1 is the Hot Water Tank Temp Probe 2 is the overflow sensor probe</p>																	

Installation Instructions

Equipment Setup

1. Read User Guide noting all instructions. Review the dimensions for the unit you are installing. Verify that it will fit in the space intended for it. Verify that the counter or table will support the total weight of the equipment and any dispensers when filled.
2. Place the equipment on the counter or stand.

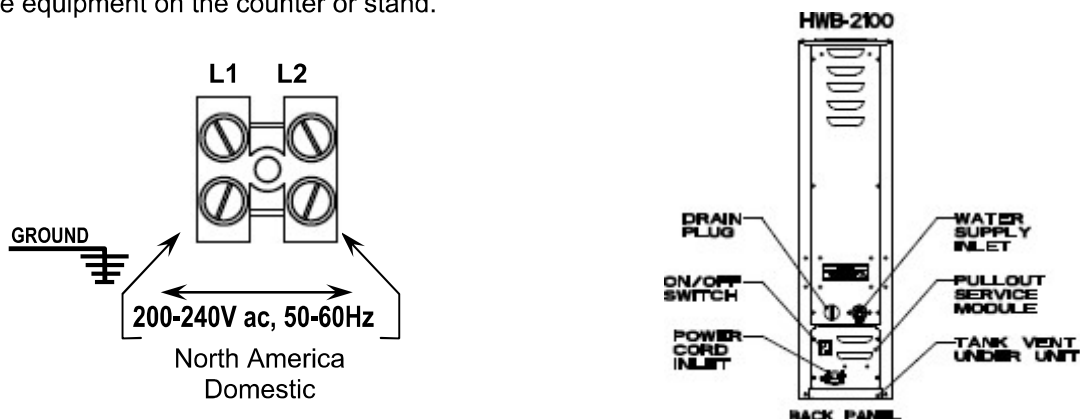

Illustrations above show examples of domestic terminal block and location of connections and utilities.

→Always refer to the wiring diagrams when connecting equipment electrical utilities

Water Connection

1. Water supply inlet is a $\frac{3}{8}$ inch male flare fitting.
2. The HWB-2100 Hot Water Dispenser can be connected to a cold or hot water line. (Cold water is preferred for best beverage flavor, but hot water will allow for greater output.)
3. Install a shut off water valve near the equipment to facilitate service. An in-line water filter should be used and installed after the water shut off valve and in a position to facilitate filter replacement.
4. Flush the water supply line and filter **before** connecting it to the unit.
5. Verify that the water line will deliver a flow rate of at least $1\frac{1}{2}$ gpm/(5.7lpm) per minute and water pressure is between 20-75 psig (138-517kPa) before making any connections.
6. Use a wrench on the factory fitting when connecting the incoming water line. This will reduce stress on the internal connections and reduce the possibility of leaks developing after the install has been completed.

Electrical Connection

1. The HWB-2100 model series requires hardwired grounded service to the terminal block (illus. 1)
2. Verify that the actual voltage at the electrical service connection is compatible with the specifications on the equipment serial number label. Make sure the electrical service match the current draw of the equipment.
3. Access the terminal block for electrical connection by removing the pullout service module on the lower back.
4. A fused disconnect switch or circuit breaker on the incoming power line must be conveniently located near the equipment and its location and markings known to the operators.
5. The body of the unit must be grounded to a suitable building ground.
6. If Cord Connected: Do not use multiple taps for the plug. Consult local codes to determine if a single circuit is required for the cord and plug installed. Do not use extension cords for commercial food equipment

Tank Drain

The water tank must be drained before maintenance procedures, and when the unit is to be relocated or shipped.

1. Disconnect power to the unit.
2. Move the unit near a sink or obtain a container to large enough to hold four gallons of water.
3. Remove the tank cover and allow the tank to cool to a safe temperature.
4. The tank drain is located on the back of the unit. Turn the drain plug one-quarter turn in either direction.
5. Pull the plug out far enough to expose the silicone tube.
6. Using pliers loosen the hose clamp and move it back over the tube.
7. Crimp the tube an inch or two away from the drain plug to prevent water from flowing.
8. Use the other hand to pull the drain plug out of the tube.
9. Release the crimped tube and allow the water to flow into the sink or container.

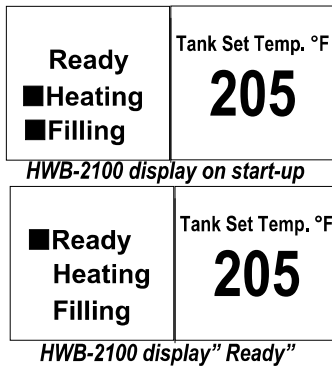

Screens shown in **Final Setup #5**

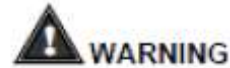

All electrical connections must be in accordance with local electrical codes and any other applicable codes.

If the supply cord is damaged, it must be replaced by the manufacturer, its service agent, or similarly qualified persons in order to avoid a hazard.

To prevent an electric shock hazard this device must be bonded to equipment in close proximity with an equipotential bonding conductor. This device is equipped with a grounding lug for this purpose and is marked with the following symbol



For "CE" marked equipment only

Final Setup

1. Turn on the incoming water supply line and inspect both inside and outside of the equipment for leaks in all fittings and tubes
2. Turn on the incoming power.
3. Turn on the power switch, located in the back of the unit.
4. Activate touch screen to turn equipment on.
5. The HWB-2100 display will show "Filling" and "Heating" icons (see illustration above) on start-up
6. The hot water tank will begin filling and will stop when the water is sensed by the probe at the top of the tank. The heaters are disabled by the control board until the tank is full. Unit may need to be restarted during first fill.
7. The temperature and water tank fill level are pre-set at the factory. There is no need to turn off the heaters during the installation process. The heaters are disabled by the control board until the tank is full of water. The heating process will start automatically when the tank has filled.
8. Heaters will turn on when covered by water. Touch Screen displays status while the water is heating—there is no "ready" light. After the water has reached the set temperature, the "ready" icon will turn on. (see ill. above)
9. Inspect for leaks. Look closely in the top and beneath the equipment and check all fittings during this inspection.

Operator Training

Review the operating procedures with whoever will be using the equipment. Pay particular attention to the following areas:

1. Show the location and operation of the water shut off valve as well as the circuit breaker for the unit.
2. We recommend leaving the power to the equipment on overnight. The water tank is well insulated and will use very little electricity to keep the tank hot. Leaving the equipment in the "on" position will also avoid delays at the beginning of shifts for the hot water dispenser to reach operating temperature.

Safety Notes

Professional installation is required. This appliance is manufactured for commercial use only.

Operation requirements and maintenance for commercial cooking appliances differ from household appliances.

Operators must be trained for this equipment and must understand the use, maintenance and kitchen hazards.

Do not attempt to move hot beverage equipment once it is filled. Drain equipment before moving.

The HWB-2100 Hot Water Boilers provides very hot water from the faucet when it is pulled.

HWB-2100 may continue to dispense very hot water from the mechanically operated faucet after the electronic touchpad is completely disabled, or if the power is turned off, or by unplugging the unit.

Keep these instructions for training and future reference

Installation safety and hygiene directions

1. Access to the service area is restricted to persons having safety/hygiene knowledge and practical experience of the coffee brewer. This appliance must be installed in locations where it can be overseen by trained personnel.
2. For proper operation, this appliance must be installed indoors where the temperature is between 10°C/50°F to 35°C/95°F. Drain and remove all liquid from equipment and lines if exposed to freezing temperatures.
3. All commercial cooking equipment, including this unit, is not intended for use by children or persons with reduced physical, sensory, or mental capabilities. Ensure proper supervision of children and keep them away from the unit.
4. Children should be supervised to ensure that they do not play hot beverage equipment.
5. This unit must be installed and serviced by qualified personnel only.
6. Installation must conform to all local electrical and plumbing codes. Installation by unqualified personnel will void the unit warranty and may lead to electric shock or burn, as well as damage to unit and/or its surroundings.
7. If the power cord requires repair or replacement-it must be performed by the manufacturer or authorized service personnel with the specified cord only from the manufacturer in order to avoid a hazard.
8. Review the dimensions for the unit and verify that it will fit properly in the space intended for it. Verify that the counter or table will support the total weight of the brewer and dispensers when filled (See: Technical Data).
9. Place the brewer on the counter or stand. When the brewer is in position, level it front to back as well as side-to-side by adjusting the legs.
10. Do not tilt appliance more than 10° to insure safe operation.
11. Unit is for protected indoor use only. Do not steam clean or use excessive water on unit.
12. This unit is not "jet-proof" construction. Do not pressure wash or use jet spray to clean this unit.
13. The unit is not waterproof-do not submerge or saturate with water.

Do not operate if unit has been submerged or saturated with water.





Equipment exposed to flood and contaminated must not be used due to electrical and food safety.

Labels and warnings for hot beverage equipment

For FRONT of equipment (1046.00036.00)

 CAUTION	 ATENCIÓN
VERY HOT WATER	AGUA MUY CALIENTE
NOTICE	AVISO
For Food Preparation	Para la preparación de alimentos

For BACK PANEL of equipment (1046.00035.00)

	WARNING	To reduce risk of electric shock or fire
	FETCO® Hot Beverage Equipment is for commercial use only.	
	Do not remove or open cover. No user serviceable parts inside. Refer installation and service to qualified personnel.	
	Caution, disconnect from power supply before servicing.	
	GROUND: National Electrical Code requires separate grounding wire	
	Use dedicated circuit with capacity rated by local code or National Electrical Code for the current draw of this equipment. Check serial number plate on right side for power requirements.	
	Locate unit away from source of heat. Do not install or use near combustibles.	
	THIS APPLIANCE IS ENERGIZED WHENEVER IT IS CONNECTED TO A POWER SOURCE	
	FAILURE TO COMPLY RISKS EQUIPMENT DAMAGE, PROPERTY DAMAGE, FIRE, OR SHOCK HAZARD	
Notice	This equipment must be installed with a backflow protection device to comply with federal, state or local municipality codes.	
Notice	Read the user guide before installing and operating this unit.	

Parts and Service drawings

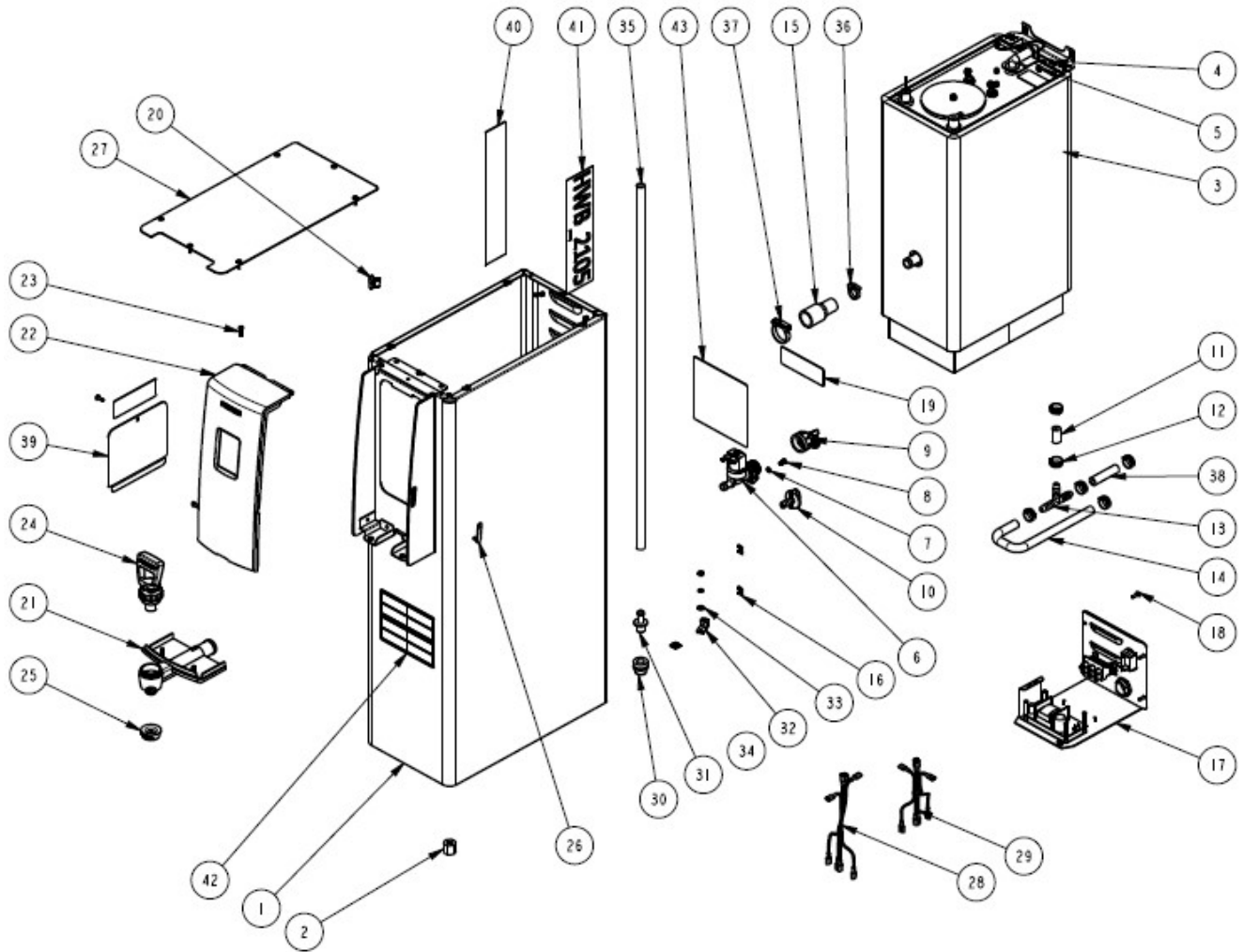

Drawing 1101.00201(229)(217).00 HWB-2105 Complete Parts

#	QTY	PART NO	DESCRIPTION
			Complete Parts Drawing 1101.00201(229)(217).00 HWB-2105
1	1	1111.00050.00	WELDMENT BODY COMPLETE, HWB-2105
2	4	1021.00018.00	LEG, TBS 2121
3	1	1104.00072.00	TANK ASSEMBLY, 3000W/240VAC, HWB-2105
3	1	1104.00078.00	TANK ASSEMBLY, 4000W/240VAC, HWB-2105
4	5	1083.00011.00	WASHER, #8 SCREW SIZE, INTERNAL TOOTH LOCK
5	5	1084.00006.00	NUT, 8-32 18-8 HEX MACHINE SCREW
6	1	1057.00059.00	VALVE, 0.66 GPM BRN FLOW REG, 180DEG/24VDC
7	2	1083.00005.00	WASHER, M4 18-8 INTERNAL TOOTH LOCKWASHER
8	2	1082.00010.00	SCREW, M4x10 ZINC PLATED PAN PHILLIPS MACHINE
9	1	1102.00243.00	ADAPTER ASSY, 3/4" BSP x 1/4" NPT x 3/8" TUBE
10	1	1023.00147.00	PLUG, TANK SERVICE DRAIN FOR 18GA AND UP BODY
11	1	1025.00061.00	TUBE, 9/16"OD X 5/16"ID X 2.75"LG
12	6	1086.00003.00	UNICLAMP, 15.9 HOSE OD CLAMP
13	1	1029.00002.00	FITTING, HOSE BARB TEE, SIZE 3/8" , NYLON
14	1	1025.00058.00	TUBE, 9/16"OD X 5/16"ID X 25.00"LG
15	1	1024.00067.00	CONNECTOR, SILICONE, TANK TO FAUCET, HWB-2100
16	10	1084.00011.00	NUT, CLIP ON (J-NUT), #6-32, 22-20 GA., BLK-PH FINISH
17	1	1102.00247.00	ASSEMBLY BACK PANEL, HWB-2105 UL
17	1	1102.00262.00	ASSEMBLY BACK PANEL, HWB-2105 CE
18	11	1082.00017.00	SCREW, # 6-32 X 1/2" TRUSS HD PHIL., MACHINE
19	1	1046.00030.00	LABEL WARNING, DISCONNECT FROM POWER SOURCE
20	2	1023.00159.00	CORNER INSERT
21	1	1023.00208.00	FAUCET BODY, HWB-2100
22	1	1102.00228.00	ASSEMBLY FRONT PANEL, HWB-2100
23	4	1082.00058.00	SCREW, # 8-32 X 5/8, FLAT HD, PH, 18-8 SS
24	1	1102.00230.00	ASSEMBLY, UPPER FAUCET, HWB-2100
25	1	1029.00029.00	FAUCET, SILICONE, HWB-2100
26	1	1024.00040.00	CARD PLUG, HWD-2100
27	1	1001.00169.00	TOP COVER, HWB 2105
28	1	1402.00067.00	HARNESS, LOW AMP, HWB-2105/2110, CE/ UL
29	1	1402.00066.00	HARNESS, HI AMP, HWB-2105 UL
30	1	1024.00050.00	GROMMET, SILICONE, 11.4mm ID
31	1	1023.00168.00	FITTING, HOT WATER, GROMMET DESIGN
32	1	1065.00009.00	GROUND LUG CONNECTOR, 14-2 AWG, ALUMINUM
33	1	1083.00016.00	WASHER, #8 SCREW SIZE, FLAT
34	1	1044.00003.00	LABEL GROUND
35	1	1025.00094.00	TUBE, 9/16 OD x 5/16 ID x 29" LG.
36	1	1086.00002.00	CLAMP, HOSE, SIZE "G" NYLON
37	1	1086.00033.00	HOSE CLAMP, NYLON BLACK, Ø1.25"-1.437" RANGE CLAMP
38	1	1025.00095.00	TUBE, 9/16 OD x 5/16 ID x 2.25 LG.
39	1	1001.00181.00	COVER FRONT, CBS-2100 XTS
40	1	1041.00021.00	LABEL FETCO, ETCHED GLASS TYPE, 10.375" L
41	1	1041.00022.00	LABEL, HWB-2105
42	1	1046.00036.00	LABEL, HOT WATER CAUTION, HWB-2100
43	1	1046.00035.00	LABEL, WARNING, HWB-2100

Complete Parts Drawing 1101.00202.00 HWB-2110			
#	QTY	PART NO	DESCRIPTION
1	1	1111.00051.00	WELDMENT BODY COMPLETE, HWB-2110
2	4	1021.00018.00	LEG, TBS 2121
3	1	1104.00073.00	TANK ASSEMBLY, 2 X 3000W/240VAC, HWB-2110
4	5	1083.00011.00	WASHER, #8 SCREW SIZE, INTERNAL TOOTH LOCK
5	5	1084.00006.00	NUT, 8-32 18-8 HEX MACHINE SCREW
6	1	1057.00059.00	VALVE, 0.66 GPM BRN FLOW REG, 180DEG/24VDC
7	2	1083.00005.00	WASHER, M4 18-8 INTERNAL TOOTH LOCKWASHER
8	2	1082.00010.00	SCREW, M4x10 ZINC PLATED PAN PHILLIPS MACHINE
9	1	1102.00243.00	ADAPTER ASSY, 3/4" BSP x 1/4" NPT x 3/8" TUBE
10	1	1023.00147.00	PLUG, TANK SERVICE DRAIN FOR 18GA AND UP BODY
11	1	1025.00061.00	TUBE, 9/16"OD X 5/16"ID X 2.75"LG
12	6	1086.00003.00	UNICLAMP, 15.9 HOSE OD CLAMP
13	1	1029.00002.00	FITTING, HOSE BARB TEE, SIZE 3/8" , NYLON
14	1	1025.00058.00	TUBE, 9/16"OD X 5/16"ID X 25.00"LG
15	1	1024.00067.00	CONNECTOR, SILICONE, TANK TO FAUCET, HWB-2100
16	10	1084.00011.00	NUT, CLIP ON (J-NUT), #6-32, 22-20 GA., BLK-PH FINISH
17	1	1102.00248.00	ASSEMBLY BACK PANEL, HWB-2110 UL
17	1	1102.00263.00	ASSEMBLY BACK PANEL, HWB-2110 CE
18	11	1082.00017.00	SCREW, # 6-32 X 1/2" TRUSS HD PHIL., MACHINE
19	1	1046.00030.00	LABEL WARNING, DISCONNECT FROM POWER SOURCE
20	2	1023.00159.00	CORNER INSERT
21	1	1023.00208.00	FAUCET BODY, HWB-2100
22	1	1102.00228.00	ASSEMBLY FRONT PANEL, HWB-2100
23	4	1082.00058.00	SCREW, # 8-32 X 5/8, FLAT HD, PH, 18-8 SS
24	1	1102.00230.00	ASSEMBLY, UPPER FAUCET, HWB-2100
25	1	1024.00040.00	CARD PLUG, HWD-2100
26	1	1001.00200.00	TOP COVER, HWB 2110
27	1	1029.00029.00	FAUCET, SILICONE, HWB-2100
28	1	1024.00050.00	GROMMET, SILICONE, 11.4mm ID
29	1	1023.00168.00	FITTING, HOT WATER, GROMMET DESIGN
30	1	1402.00067.00	HARNESS, LOW AMP, HWB-2105/2110, CE/ UL
31	1	1402.00065.00	HARNESS, HI AMP, HWB-2110 UL
32	1	1065.00009.00	GROUND LUG CONNECTOR, 14-2 AWG, ALUMINUM
33	1	1083.00016.00	WASHER, #8 SCREW SIZE, FLAT
34	1	1044.00003.00	LABEL GROUND
35	1	1025.00094.00	TUBE, 9/16 OD x 5/16 ID x 29" LG.
36	1	1086.00002.00	CLAMP, HOSE, SIZE "G" NYLON
37	1	1086.00033.00	HOSE CLAMP, NYLON BLACK, Ø1.25"-1.437" RANGE CLAMP
38	1	1025.00095.00	TUBE, 9/16 OD x 5/16 ID x 2.25 LG.
39	1	1001.00181.00	COVER FRONT, CBS-2100 XTS
40	1	1041.00021.00	LABEL FETCO, ETCHED GLASS TYPE, 10.375" L
41	1	1041.00023.00	LABEL, HWB-2110
42	1	1046.00035.00	LABEL, WARNING, HWB-2100
43	1	1046.00036.00	LABEL,HOT WATER CAUTION, HWB-2100

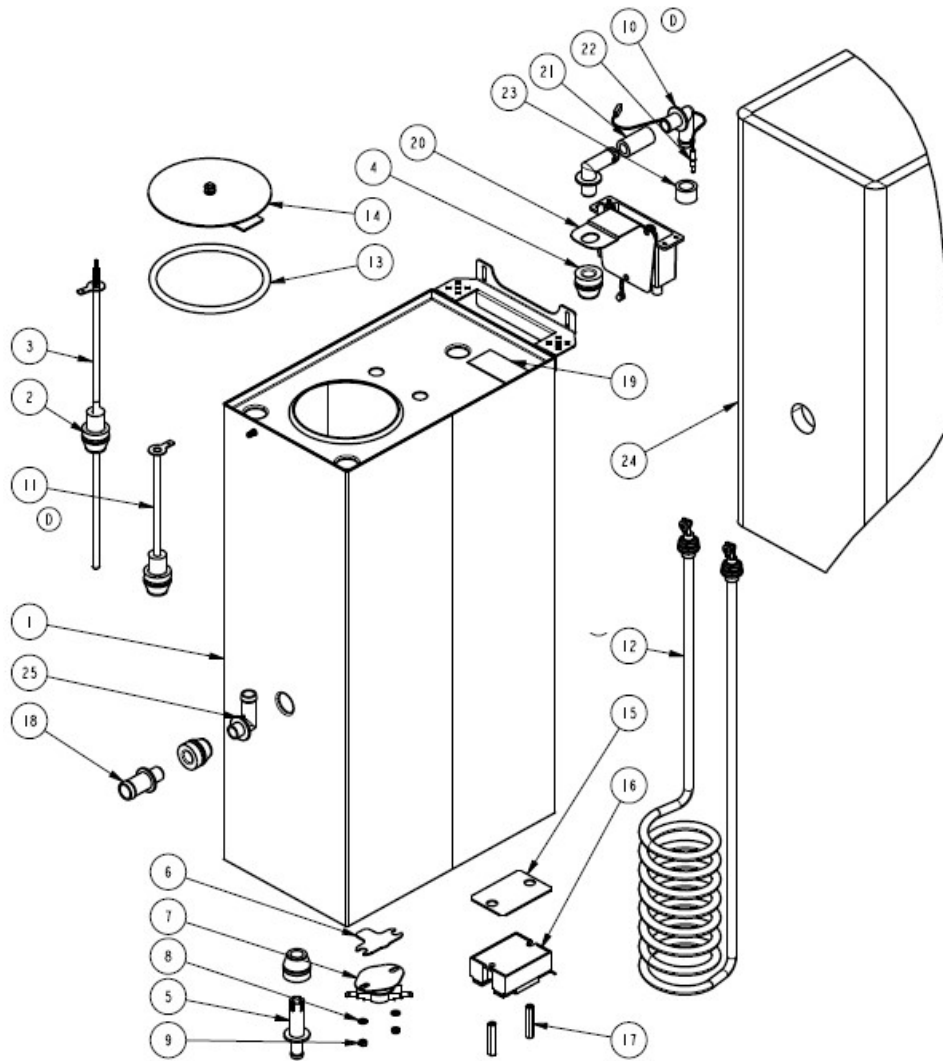

HWB-2105 Hot Water Tank Drawing 1104.00072(78)

HWB-2105 Hot Water Tank Drawing 1104.00072(78)			
#	QTY	PART NO	DESCRIPTION
1	1	1114.00107.00	WELDMENT, TANK, HWB-2105
2	2	1024.00053.00	LEVEL AND TEMP PROBE GROMMET
3	1	1102.00234.00	PROBE ASSEMBLY, TEMP. AND LLC 12" LONG
4	3	1024.00050.00	GROMMET, SILICONE, 11.4mm ID
5	1	1023.00166.00	FITTING, COLD WATER INLET, GROMMET DESIGN
6	1	1003.00005.00	BRACKET, ONE SHOT THERMOSTAT
7	1	1053.00004.00	THERMOSTAT, SINGLE SHOT, 25A
8	2	1083.00009.00	WASHER, #6 SCREW , INTL TOOTH LOCKWASHER
9	2	1084.00010.00	NUT, HEX, #6-32, UNDERSIZED, ZINC PLATED
10	2	1023.00212.00	FITTING, VENTING BOX
11	1	1112.00336.00	PROBE WELDMENT, WATER LEVEL 5.00" LG
12	1	1107.00034.00	HEATER ASSEMBLY, IMMERSION 3000W/240VAC
12	1	1107.00035.00	HEATER ASSEMBLY, IMMERSION 4000W/240VAC
13	1	1024.00007.00	O-RING, DASH #344, TANK COVER
14	1	1102.00007.00	TANK COVER ASSEMBLY
15	1	1003.00140.00	ALUMINUM BRACKET FOR SSR
16	1	1052.00033.00	RELAY, SOLID STATE, 50A/480VAC, W/BUILD IN VARISTOR
17	2	1081.00042.00	STANDOFF, 1/4" HEX
18	1	1023.00203.00	FITTING, BREW, GROMMET DESIGN
19	1	1044.00004.00	LABEL, DANGER-HIGH VOLTAGE
20	1	1102.00244.00	ASSEMBLY, VENTING BOX
21	1	1025.00022.00	TUBE, 5/8"OD X 3/8"ID X 1.25"LG, BY-PASS
22	1	1102.00242.00	ASSEMBLY, TEMPERATURE SENSOR
23	1	1025.00089.00	TUBING, 1/2ID X 3/4OD X 1/2 LG.
24	1	1022.00078.00	TANK INSULATION, HWB-2105
25	1	1023.00222.00	FITTING, FLOW RESTRICTOR, HWB-2100 TANKS

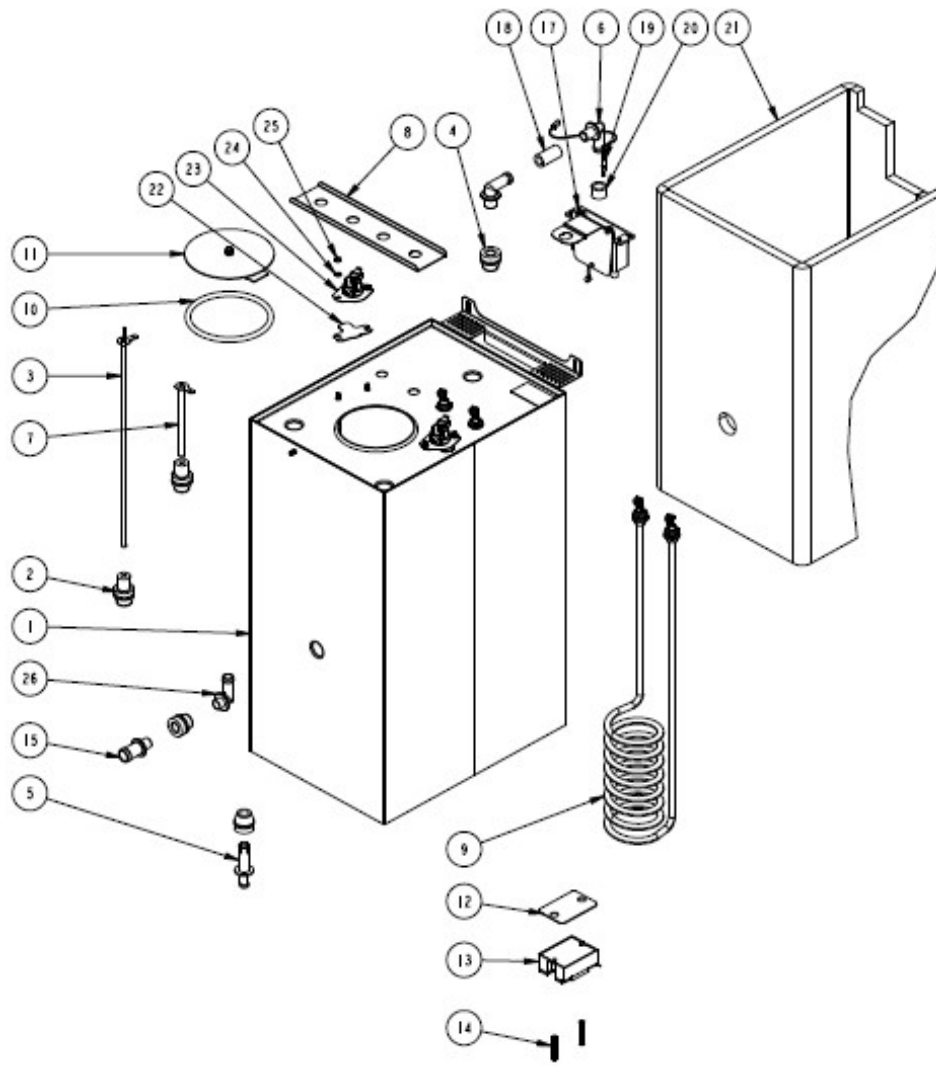

HWB-2110 Hot Water Tank Drawing 1104.00077(73).00			
#	QTY	PART NO	DESCRIPTION
1	1	1114.00111.00	WELDMENT TANK, HWB-2110
2	2	1024.00053.00	LEVEL AND TEMP PROBE GROMMET
3	1	1102.00234.00	PROBE ASSEMBLY, TEMP. AND LLC 12" LONG
4	3	1024.00050.00	GROMMET, SILICONE, 11.4mm ID
5	1	1023.00166.00	FITTING, COLD WATER INLET, GROMMET DESIGN
6	2	1023.00212.00	FITTING, VENTING BOX
7	1	1112.00336.00	PROBE WELDMENT, WATER LEVEL 4.00" LG
8	1	1002.00127.00	BRACKET STIFFENER TANK TOP - 2110
9	2	1107.00034.00	HEATER ASSEMBLY, IMMERSION 3000W/240VAC
9	2	1107.00035.00	HEATER ASSEMBLY, IMMERSION 4000W/240VAC
10	1	1024.00007.00	O-RING, DASH #344, TANK COVER
11	1	1102.00007.00	TANK COVER ASSEMBLY
12	2	1003.00140.00	ALUMINUM BRACKET FOR SSR
13	2	1052.00033.00	RELAY, SOLID STATE, 50A/480VAC, W/BUILD IN VARISTOR
14	4	1081.00042.00	STANDOFF, 1/4" HEX
15	1	1023.00203.00	FITTING, BREW, GROMMET DESIGN
16	1	1044.00004.00	LABEL, DANGER-HIGH VOLTAGE
17	1	1102.00244.00	ASSEMBLY, VENTING BOX
18	1	1025.00022.00	TUBE, 5/8"OD X 3/8"ID X 1.25"LG, BY-PASS
19	1	1102.00242.00	ASSEMBLY, TEMPERATURE SENSOR
20	1	1025.00089.00	TUBING, 1/2ID X 3/4OD X 1/2 LG.
21	1	1022.00079.00	TANK INSULATION, HWB-2110
22	2	1003.00005.00	BRACKET, ONE SHOT THERMOSTAT
23	2	1053.00003.00	THERMOSTAT, SINGLE SHOT, 240V/40A
24	4	1083.00009.00	WASHER, #6 SCREW , INTL TOOTH LOCKWASHER
25	4	1084.00010.00	NUT, HEX, #6-32, UNDERSIZED, ZINC PLATED
26	1	1023.00222.00	FITTING, FLOW RESTRICTOR, HWB-2100 TANKS

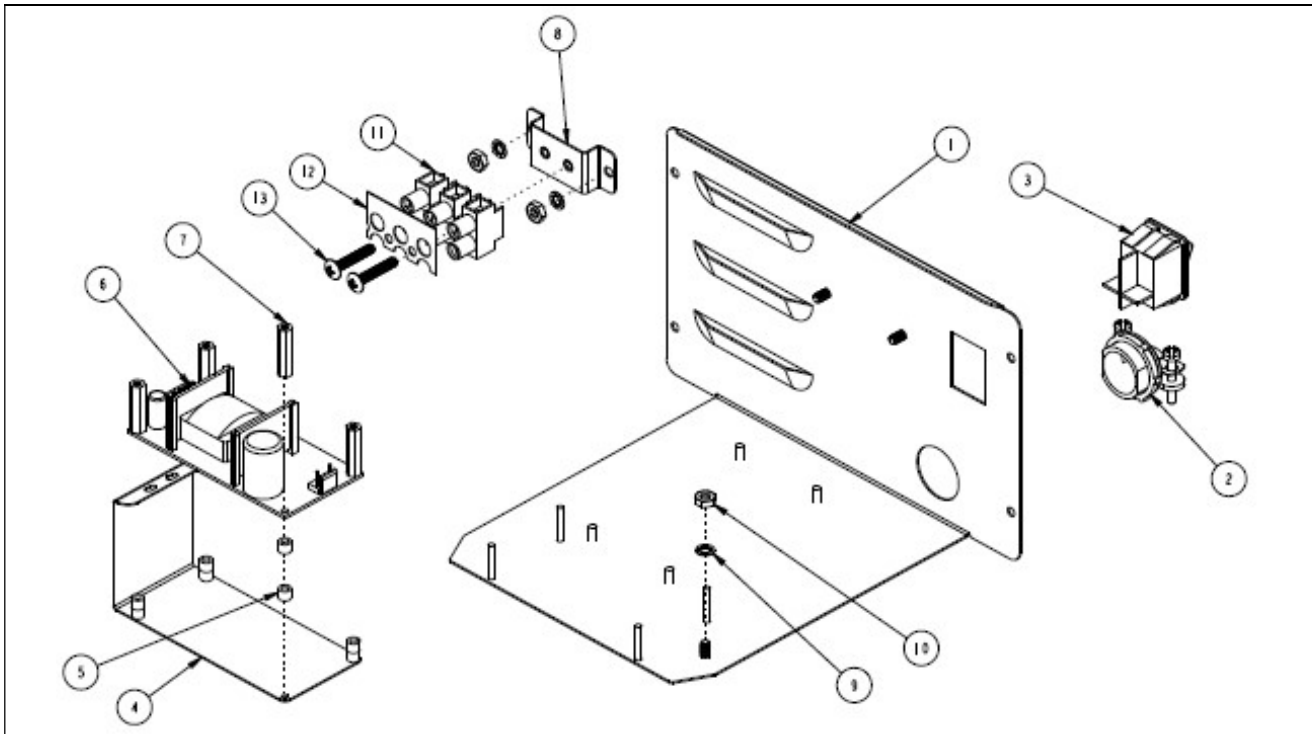

#	QTY	PART NO	DESCRIPTION
		1102.00248.00	ASSEMBLY BACK PANEL, HWB-2110 UL
1	1	1112.00317.00	WELDMENT BACK PANEL, HWB-2110
2	1	1086.00008.00	CONNECTOR, CABLE CLAMP, 3/4"
3	1	1058.00024.00	SWITCH, POWER, DOUBLE POLE, 16A, 125/250 VAC
4	1	1003.00170.00	BRACKET, GUARD
5	8	1081.00006.00	SPACER, 6MM OD x 3.2MM ID x 5MM LG, Z/P
6	1	1052.00001.00	POWER SUPPLY, 90-264VAC/24VDC, 1.8A
7	4	1029.00012.00	SPACER, .25" HEX X 1" LG, FEM #4-40 THREAD
8	1	1112.00246.00	WELDMENT BRACKET TERMINAL BLOCK, 3 POLE
9	1	1083.00011.00	WASHER, #8 SCREW SIZE, INTERNAL TOOTH LOCK
10	3	1084.00006.00	NUT, 8-32 18-8 HEX MACHINE SCREW
11	1	1052.00022.00	EUROSTRIP HE6 TERM. BLK., 3 POLE, 40AMP, 10-20 TERM. BLK
12	1	1052.00025.00	PLATE, MARKING #BS1016E
13	1	1082.00082.00	SCREW, PHILLIP HD., 8-32 THREAD

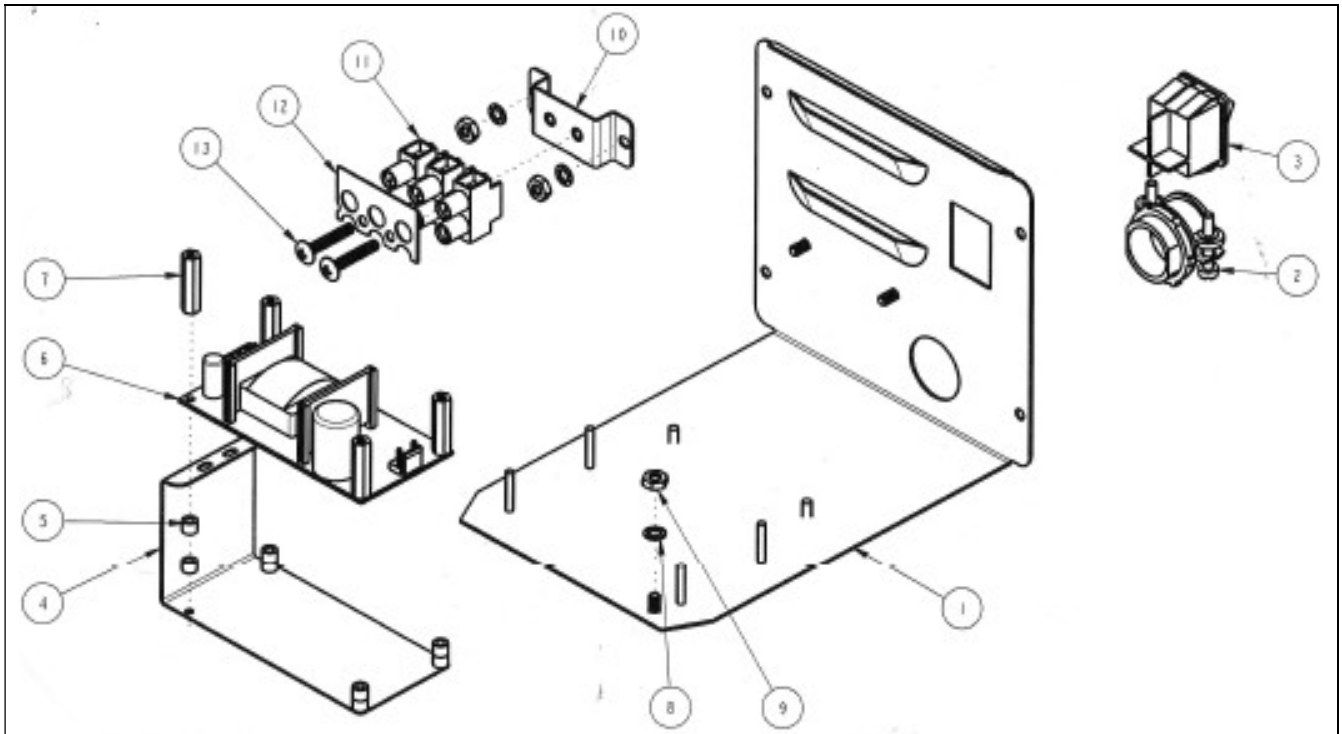

#	QTY	PART NO	DESCRIPTION
			1102.00247.00 ASSEMBLY BACK PANEL, HWB-2105 UL
1	1	1112.00313.00	WELDMENT BACK PANEL, HWB-2105
2	1	1086.00008.00	Cable Back Connector 3/4"
3	1	1058.00024.00	SWITCH, POWER, DOUBLE POLE, 16A, 125/250 VAC
4	1	1003.00170.00	BRACKET, GUARD
5	8	1081.00006.00	SPACER, 6MM OD x 3.2MM ID x 5MM LG, Z/P
6	1	1052.00001.00	POWER SUPPLY, 90-264VAC/24VDC, 1.8A
7	4	1029.00012.00	SPACER, .25" HEX X 1" LG, FEM #4-40 THREAD
8	3	1083.00011.00	WASHER, #8 SCREW SIZE, INTERNAL TOOTH LOCK
9	3	1084.00006.00	NUT, 8-32 18-8 HEX MACHINE SCREW
10	1	1112.00246.00	WELDMENT BRACKET TERMINAL BLOCK, 3 POLE
11	1	1052.00022.00	EUROSTRIP HE6 TERM. BLK., 3 POLE, 40AMP, 10-20 TERM. BLK.
12	1	1052.00025.00	PLATE, MARKING #BS1016E
13	2	1082.00082.00	SCREW, PHILLIP HD., 8-32 THREAD

Wiring Diagrams

Follow

PROPRIETARY AND CONFIDENTIAL.
 THE INFORMATION CONTAINED IN THIS DRAWING IS THE SOLE PROPERTY OF FETCO.
 ANY REPRODUCTION IN PART OR AS A WHOLE WITHOUT THE WRITTEN PERMISSION OF FETCO IS PROHIBITED.

REVISIONS				
REV	DATE	ECO NO	DESCRIPTION	BY:
A	04/02/2014	N/A	ORIGINAL	AG
B	07/08/2014	N/A	REVISED	SZ
C	10/10/2014	N/A	REVISED	SZ

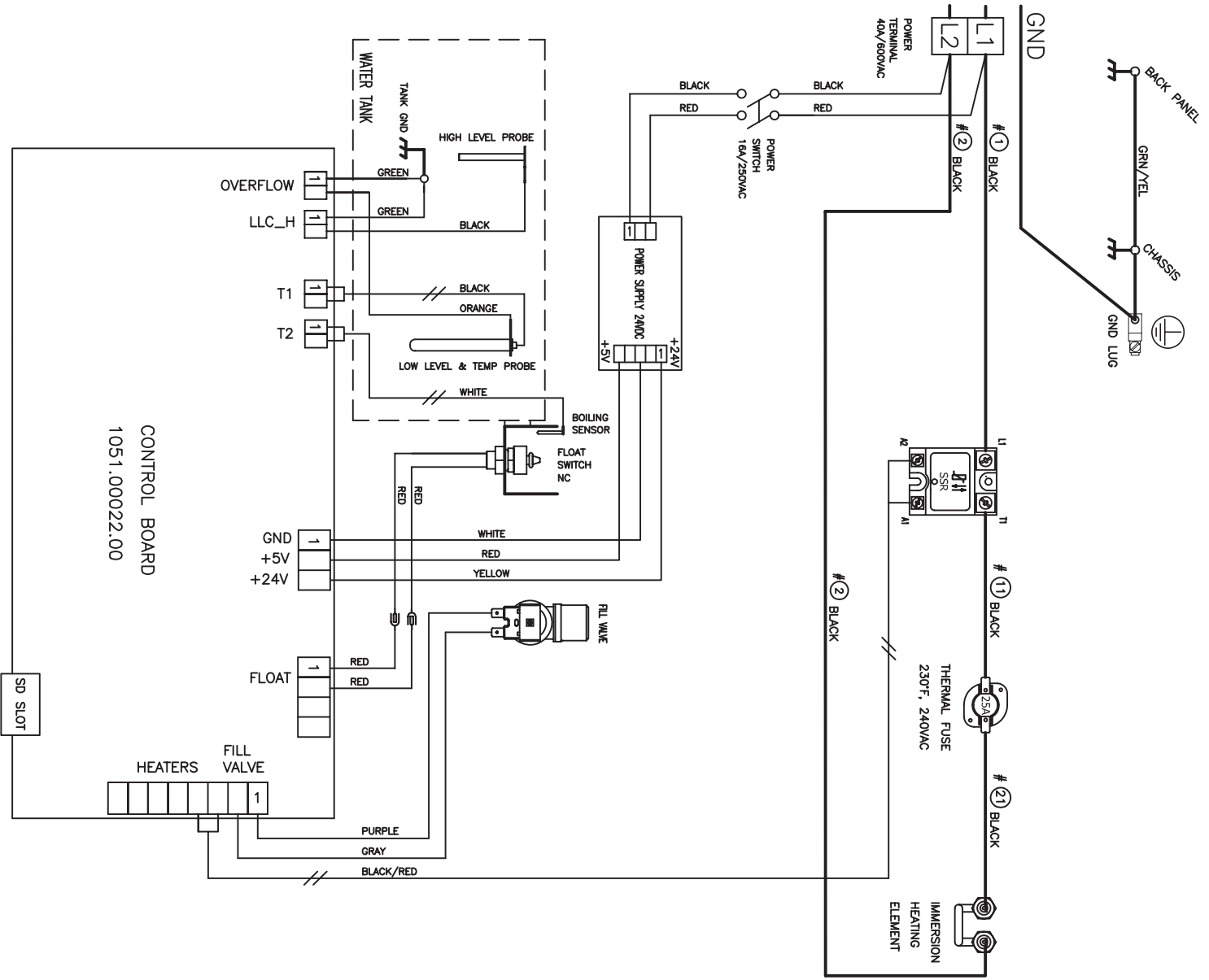

CONTROL BOARD
 1051.00022.00

TOLERANCES	REVISIONS			FETCO®	FOOD EQUIPMENT TECHNOLOGY COMPANY 600 ROSE RD. LAKE ZURICH, IL 60047 PHONE: 847-719-3000, FAX: 847-719-3001 WWW.FETCO.COM				
	EXCEPT AS NOTED	NO.	DATE		BY	DWG. NAME:	SCALE	MATERIAL	
DECIMAL		A	04-02-14	AG	WIRING, HWB-2105, L1-L2-GND, UL 1 HEATER	N/A	N/A		
N/A		B	07-08-14	SZ					
FRACTIONAL		C	10-10-14	SZ					
N/A		D			DRAWN BY	AG	SIZE	A	
ANGULAR		E			CHK'D	SZ	DATE	07-08-2014	
N/A					APP'D	LW			
							DRAWING NO.		1401.00089.00

PROPRIETARY AND CONFIDENTIAL.
 THE INFORMATION CONTAINED IN THIS DRAWING IS THE SOLE PROPERTY OF FETCO.
 ANY REPRODUCTION IN PART OR AS A WHOLE WITHOUT THE WRITTEN PERMISSION OF FETCO IS PROHIBITED.

REVISIONS				
REV	DATE	ECO NO	DESCRIPTION	BY:
A	04/02/2014	N/A	ORIGINAL	AG
B	08/01/2014	N/A	REVISED	SZ
C	10/10/2014	N/A	REVISED	SZ

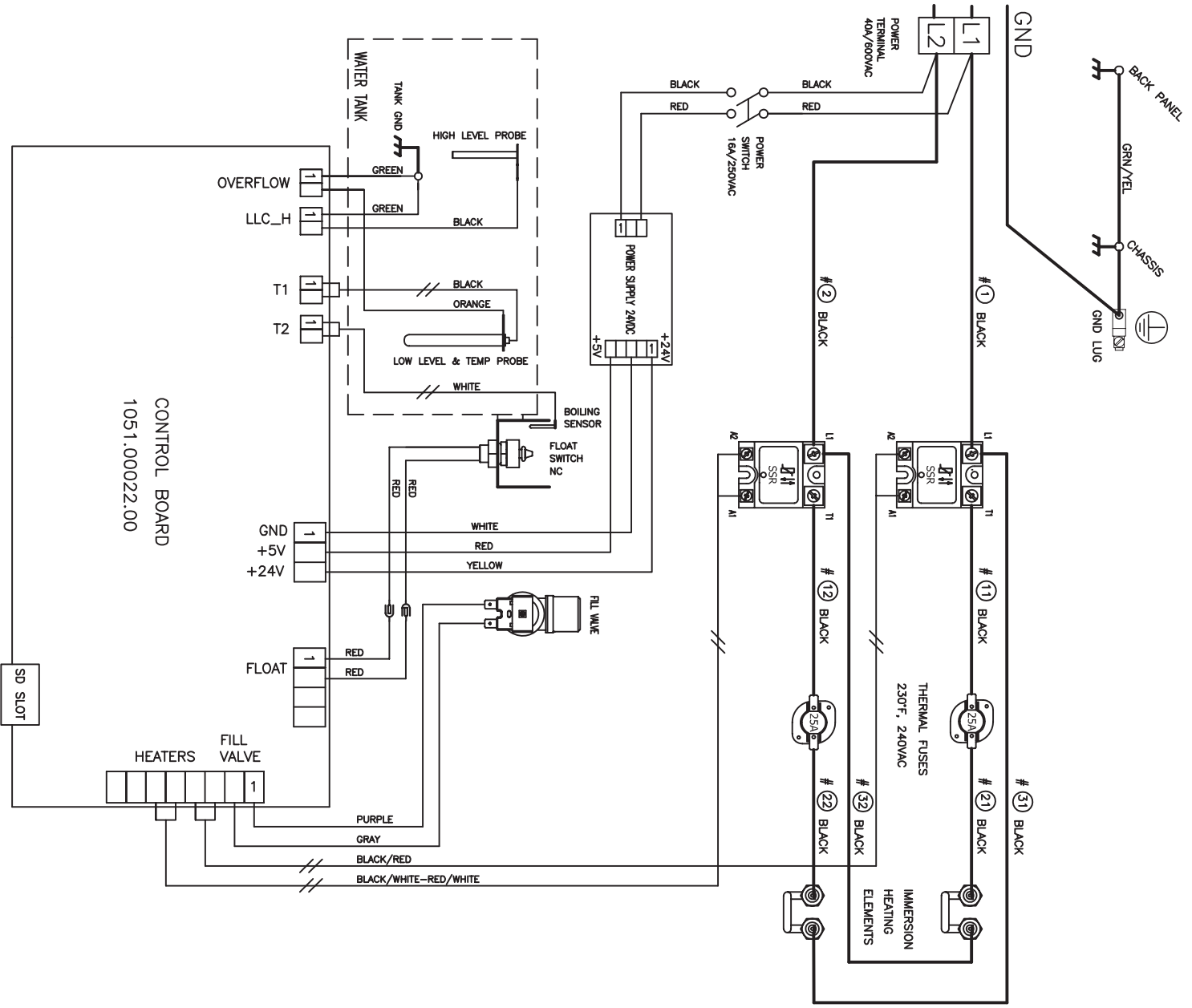

TOLERANCES	REVISIONS			FETCO®	FOOD EQUIPMENT TECHNOLOGY COMPANY 600 ROSE RD. LAKE ZURICH, IL 60047 PHONE: 847-719-3000, FAX: 847-719-3001 WWW.FETCO.COM		
	NO.	DATE	BY		DWG. NAME:	SCALE	MATERIAL
EXCEPT AS NOTED	A	04-02-14	AG	WIRING, HWB-2110, L1-L2-GND, UL 2 HEATERS	N/A	N/A	
DECIMAL	B	08-01-14	SZ				
FRACTIONAL	C	10-10-14	SZ				
ANGULAR	D			DRAWN BY	AG	SIZE	A
	E			CHK'D	SZ	DATE	08-01-2014
				APP'D	LW	DRAWING NO. 1401.00088.00	